

digital audio
weiss engineering ltd.
Florastrasse 42, 8610 Uster, Switzerland
☎ +41 1 940 20 06 📠 +41 1 940 22 14
🌐 <http://www.weiss.ch> / <http://www.weiss-highend.com>



GAMBIT

DS1

OPERATING MANUAL

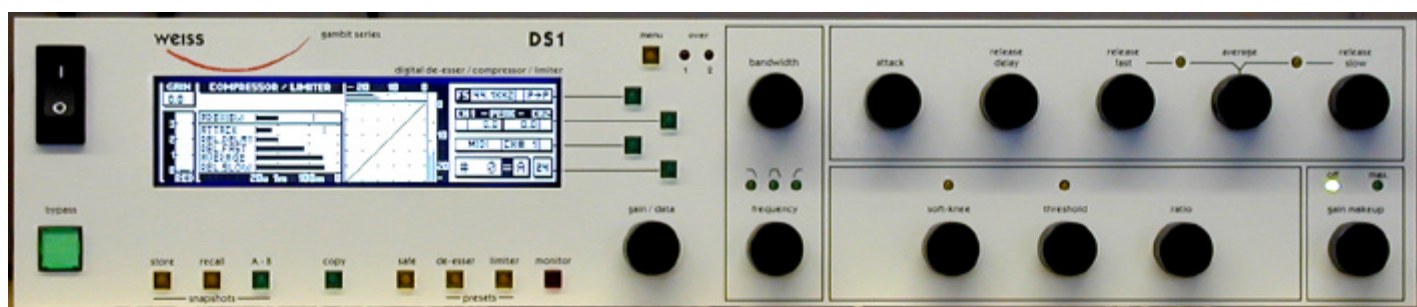

Software Version: OS: 1.1
DSP: 1.0

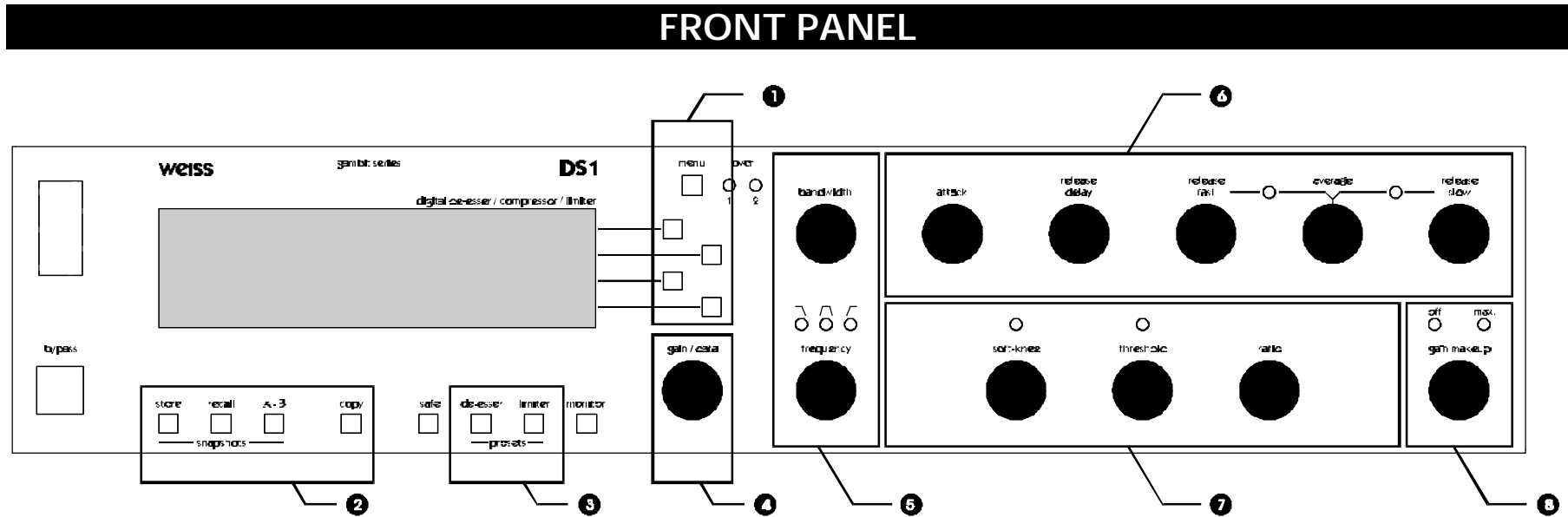

Graphic 1: Front Panel Elements

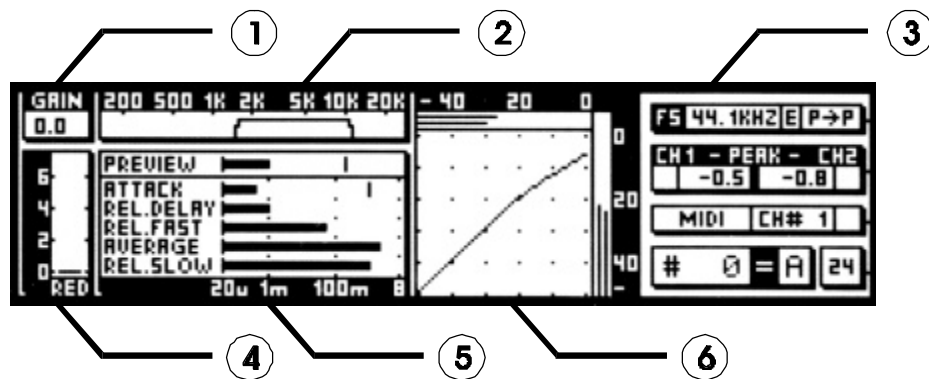

Graphic 2: Display Elements

Front Panel Groups

The front panel of the DS1 offers several control and display features.

Control

Refer to Graphic 1: Front Panel Elements

- | | | |
|-------|-----------------------------------|-------|
| ❶ | - Menu- and softkeys | p. 5 |
| ❷ | - Snapshot keys | p. 11 |
| ❸ | - Preset keys | p. 11 |
| ❹ | - Gain / Data knob | p. 6 |
| ❺ | - Crossover knobs | p. 10 |
| ❻ | - Envelope detection knobs | p. 8 |
| ❼ + ❽ | - Non-linear transfer curve knobs | p. 9 |

Display

Refer to Graphic 2: Display Elements

- | | | |
|---|-------------------------------------------------|-------|
| ❶ | - Gain value | p. 6 |
| ❷ | - Crossover setting | p. 10 |
| ❸ | - Status display | p. 5 |
| ❹ | - Gain reduction meter | p. 9 |
| ❺ | - Envelope detection settings | p. 8 |
| ❻ | - Non-linear transfer curve and signal metering | p. 9 |

INTRODUCTION

Congratulations on purchasing the Weiss Gambit Series DS1 De-esser / Compressor !

This two channel digital De-esser/Compressor features linear-phase crossover filters covering the whole audio band. Thus the DS1 is not just a De-esser but can also be used as band selective or full band Compressor / Limiter. The controls for the two channels are always ganged and the sidechains are always linked.

Specialities of the De-esser mode are absolute transparency if no gain reduction is applied, fully adjustable transfer curve and timing section and four-times upsampling for high frequency transient detection and a selectable working band.

In Compressor mode, the DS1 uses double-sampling signal processing for the whole compressor section (not only transient detection) yielding extremely reliable limiting functions and low signal modulation distortion even for fast timing settings. Valuable parameters like soft-knee and auto gain makeup facilitate reaching exactly the sound you want.

The large CFL LC display and the one-knob-per-parameter operation combine speed and ease of use with complete control over audio processing.

This and the ability to remote control parameters and snapshots makes the DS1 the perfect tool for the recording and mastering engineer!

Processing

- * 24bit digital I/O, dithered output for 16bit or 20bit wordlengths.
- * Transparent phase-linear crossover for frequency selective compression
- * All parameters are immediately accessible with instant feedback through LEDs and the LC display.

Display

- * Standardized peak meters for compressor-stage in- and output with peak hold
- * Gain reduction meter with peak hold
- * Double logarithmic graph of the transfer function of the de-esser/compressor calculated in real time
- * Status display showing sampling frequency, channel status data handling, current workspace and snapshot number and a resettable peak-hold and over-hold per channel
- * Parameter display (activated by touch) showing all timing, level and gain parameters
- * Signal status LEDs, showing OVERs, range of envelope signal and the status of the release time comparator

Snapshots

- * 3 x 128 non-volatile snapshots where all parameters are stored
- * A-B workspaces for quick comparison between two settings

Remote Control

- * Supports MIDI, RS-232 and RS-422 protocols
- * Standard MIDI Continuous Controllers for parameter remote control (including overall gain)
- * Snapshot automatization with MIDI Program Change Commands
- * MIDI Dump of Snapshots

OPERATION

The following explanations assume that the de-esser/compressor is in power-up mode, i.e. no menu is active. If a menu is active, press the "menu" key repeatedly until the status display appears.

Status Display

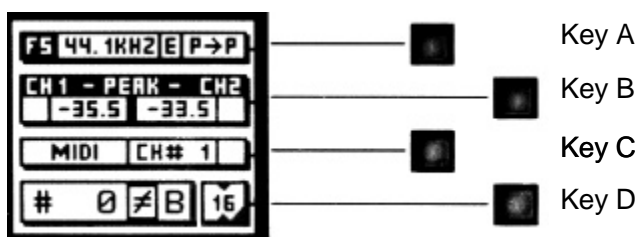

Graph 3: Status Display

The status display (Graph 3) consists of four groups displaying audio signal properties and information about the current state of the DS1.

Channel Status Group

Situated adjacent to key A, displays the following information:

- ✦ sampling frequency in kHz: either "44.1" or "48"
- ✦ pre-emphasis: "E" appears if pre-emphasis is set (empty if not used)
- ✦ input → output channel status data format: "C" for consumer and "P" for professional

To change the output channel status data format, press key A and select format type or loop through.

Peak Group

Situated adjacent to key B, this group contains a peak-hold and an over-hold for each channel. To reset these values press key B twice.

Peak-Hold

The numeric peak value is measured relative to 0dBFS (digital full scale).

Use this value to set the optimum gain for a specific session. Reset it for every session by pressing key B twice.

Over-Hold

Whenever an over is encountered, the boxes to the side of the peak-hold values are marked.

The functions of the over-LED's and the over-hold both depend on the NUMBER OF CONSECUTIVE OVER-SAMPLES setting. To adjust this setting, press key B once. Use the gain/ data knob (Ⓐ) to change the value, then press "menu" to return to the status display.

This setting defines the number of consecutive over-samples needed for an over-indication. To indicate every over-sample, enter 1. If another value is entered, you are still able to detect a single over-sample with the peak-hold function.

Over-samples are defined as exceeding the integer range. A full scale signal (0dBFS) will not be treated as over.

Remote Group

Situated adjacent to key C, displays remote control protocol ("MIDI", "RS 232" or "RS 422"), channel ("1" - "16") and status (on/ off, displayed with check box).

For setup see chapter Remote Control.

Snapshot Display

Bottom line in the status display. Refer to this for information on current workspace and snapshot. There are two workspaces ("A" and "B") for quick comparison of two de-esser/compressor settings. A workspace can be stored to a snapshot for later use.

The number of the last recalled snapshot will be displayed. If you change any value after the recall, the "=" will change to "≠" to symbolize that the workspace is not equal to the displayed snapshot anymore.

For snapshot handling see chapter Snapshots (p. 11).

Dither Icon

The dither icon is situated right next to key D (see Graph 3). If dither is off, the icon contains the number "24", the word length of the output signal in bits. Turning dither on will produce arrows above and below the new word length

number ("16" or "20"). Additionally, if auto-blackening is enabled, the bottom right corner of the icon is inverted.

For details on dither refer to chapter Dither (p. 11).

Overall Gain

An overall gain can be applied to the output signal. This gain is always active, regardless of mode or compressor settings, but can be bypassed with the bypass key.

To change gain, set the value with the gain / data knob (④). The current value is shown in ①.

Compressor Parameters

Following is a detailed description of all parameters that can be adjusted in the compressor stage. Guidelines are given for settings (see also the presets), but optimal settings are usually extremely programme dependent, so experimenting and listening is inevitable for satisfying results.

Graphic 4 shows schematic and parameters of the DS1 compressor stage:

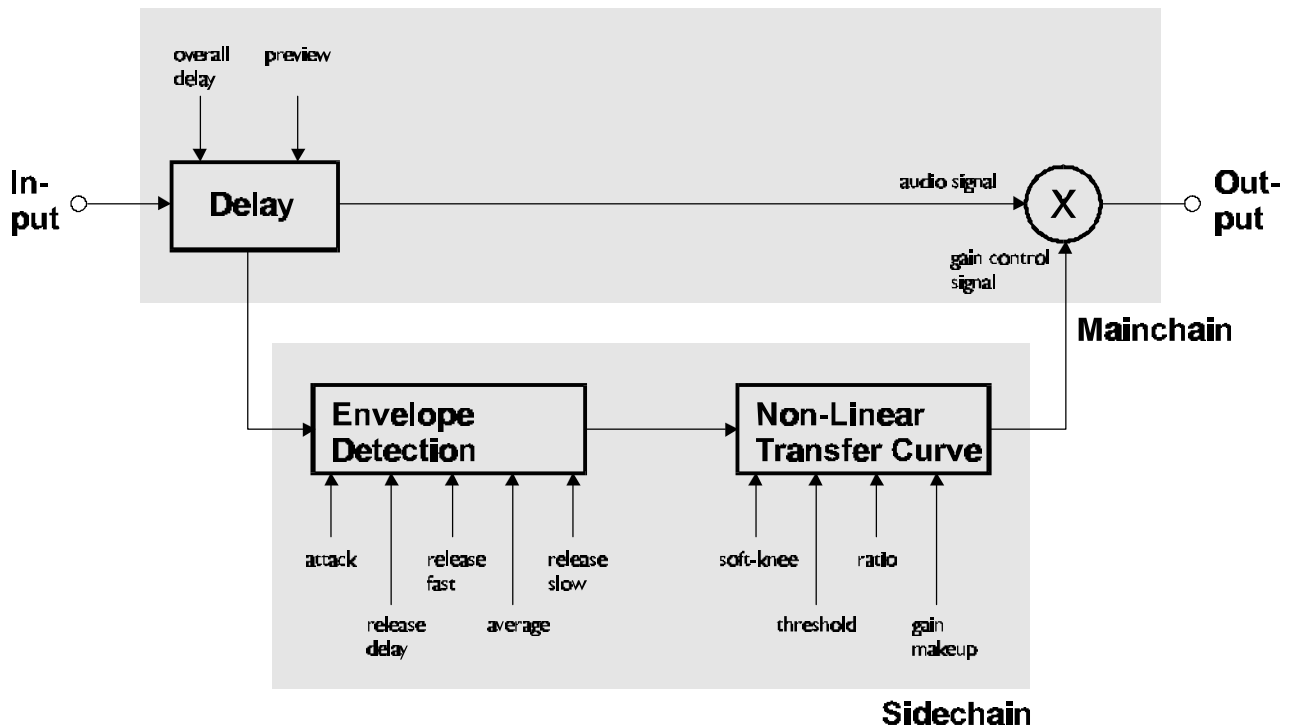

Graphic 4: Compressor schematic

Delay

A typical compressor/limiter circuit measures the audio signal and then generates the gain reduction control signal. At the time the control signal changes the gain, the programme material is already there, so the gain change occurs too late. The result is overshoot and possible subsequent distortion.

The DS1 uses a different method to generate the gain control signal: The audio passing through the mainchain is delayed by a fixed amount of time, determined by the „overall delay“. By branching the signal out of the delay line, the sidechain „sees“ the signal before it reaches the output, thus allowing look-ahead compared to the mainchain. The resulting corrected output signal has no overshoots, no leading edge distortion or

other side effects due to timing lags in the sidechain.

The preview (the time the signal reaches the sidechain ahead of the multiplier) cannot, of course, exceed the overall delay.

The overall delay is the sum of the maximum preview („Delay“ in Graphic 4) and the delay required for other signal processing (linear-phase filtering). Any snapshot value of the preview delay which exceeds this maximum, is clipped to the maximum, because the overall delay is not stored in the snapshots and therefore the preview delay in any snapshot can exceed the currently selected overall delay.

Setting overall delay: The overall delay is adjusted by pressing the „menu“ key (M) then selecting the „system“ and the „overall delay“ option. Use the gain / data knob (D) to change the

delay value. Maximum consequential preview time and delay in frames is also displayed. Please note that during delay change, audio is muted to avoid audio signal cuts.

Setting preview: Touch either the „attack“ or „release delay“ knob (6) to activate the timing 1 window, then use the gain / data knob (4) to adjust preview time.

Envelope Detection

The envelope detection parameter knobs are in area 6. The purpose of the envelope detection is to cause gradual gain changes, thus eliminating distortion. The current values are shown in 5.

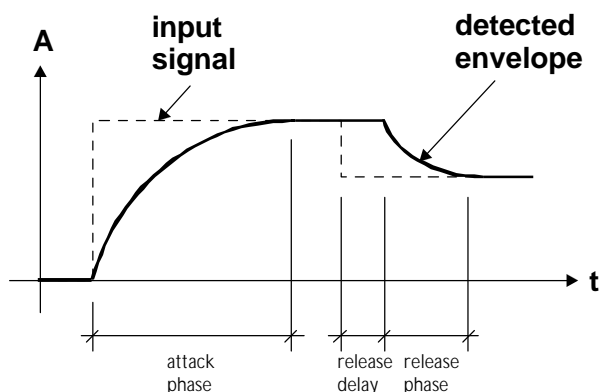

Graphic 5: Envelope Parameters

Attack and Preview: The longer the attack time, the more will the leading edge of fast transients pass by the gain reduction circuit unaltered (as in Graphic 5 during attack phase). Very fast attack time settings such as 20µs, i.e. one sample period, do catch every transient, but may distort low frequencies. To utilize longer attack times and still catch fast transients, use preview.

Note:

attack phase \cong 3 x attack time parameter

Thus, setting a preview of about 3 to 4 times the length of the attack time parameter (as seen in the parameter window of the display when touching the attack knob) should catch leading edges.

Using a smaller preview value will pass short transients (punchier sound). In this case however, gain makeup needs to be set manually to counter overs. Experimenting will be necessary for best results.

Release and Average: The input signal is monitored with two different methods: peak amplitude and RMS value. The peak amplitude is the programme portion we don't perceive as very loud, however which can easily cause overloads. The RMS value of the programme material we perceive as loudness. Its variations contribute most to the dynamic range of the audio.

The sidechain processor compares the two measurements it obtained from the peaks and the RMS. The ratio between the two determines which time constant would be the appropriate release, e.g. after short duration peak the faster release will be applied during the release phase.

The time period over which the RMS value of the programme material is averaged is set by the "average" parameter. The effect of the average parameter can best be studied on the gain reduction meter (4). Fast "average" settings will cause most of the gain reduction meter to move very fast (depending on the "release fast" setting), slower settings will just have the top part of the gain reduction move fast, with the bottom part depending on the "release slow" setting.

Release Delay: Normally the release phase begins immediately after the programme material has fallen in level. The release delay determines how long the DS1 holds the current level before entering release (see Graphic 5).

The resulting dynamic characteristic is very smooth and avoids otherwise typical 'pumping' effects. The ideal setting is programme dependent and experimentation may be necessary to achieve the best combination of all dynamic parameters.

Non-Linear Transfer Curve

The transfer curve parameter knobs are in area ⑦. This part of the sidechain is responsible for the actual gain reduction calculations. The detected signal envelope is compared with the transfer curve, the gain control signal (see Graphic 4) is then adjusted accordingly if the envelope overshoots the transfer curve.

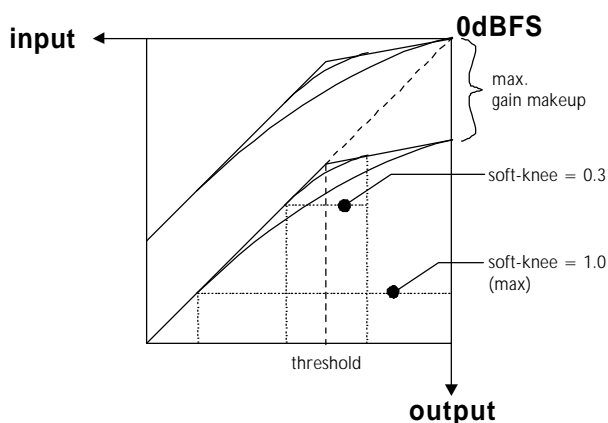

Graphic 6: Transfer Curve Parameters

Threshold: Sets the level which the envelope signal has to reach before gain reduction is applied.

Ratio: Sets the steepness of the segment above the threshold.

Soft-knee: Determines how much the knee is rounded. The maximum setting (1.0) chooses a curve that reaches from 0dBFS down to twice the threshold value. This implies that the signal is already affected even if its envelope lies below the threshold if soft-knee is engaged.

Gain makeup ⑧: Moves the whole transfer curve up or down. In de-essing mode the gain makeup is usually set between the minimum (-10dB gain) and "off" (0dB gain) to actually attenuate the processed signal, while in compressor (full band) mode the transfer curve usually gets to lie anywhere between "off" and "max", according to the amount of loudness correction one wants to apply.

Once "max." is on, the transfer curve sticks with its end to 0dBFS for maximum possible gain. "max" is engaged as soon as the curve reaches 0dBFS by manipulating any combination of the above parameters, or by selecting "max" from the gain makeup menu. This mode can be exited by manually reducing the gain makeup or by selecting "off" from the gain makeup menu.

The gain reduction needed to keep the envelope signal on the transfer curve is displayed in ④.

Signal Meters: The meters in ⑥ show the level of the input (horizontally on top of the transfer curve graph) and output of the compressor stage (vertically to the right of the transfer curve). Refer to Graphic 7 and Graphic 8 to see metering points.

Band Selective Mode vs. Full Band Mode

The DS1 operates in two basic modes, depending on the setting of the crossover.

How to change modes: Touch the centre frequency or bandwidth knob (Ⓣ). The softkeys become selection keys for the filter type: high-pass, bandpass, lowpass or bypass. In bypass the full range mode (compressor) is selected. Any other filter type engages the appropriate filter ahead of the compressor stage.

Pressing this key allows you to listen directly to the processed band, ideal for zooming in on offending material and listening to the effect of the compressor stage.

If monitor is active, the output peak hold and the over detection run on the monitor signal, not on the main output!

Also, the input and output meters on the transfer graph (Ⓣ) are connected after the crossover and before the adder.

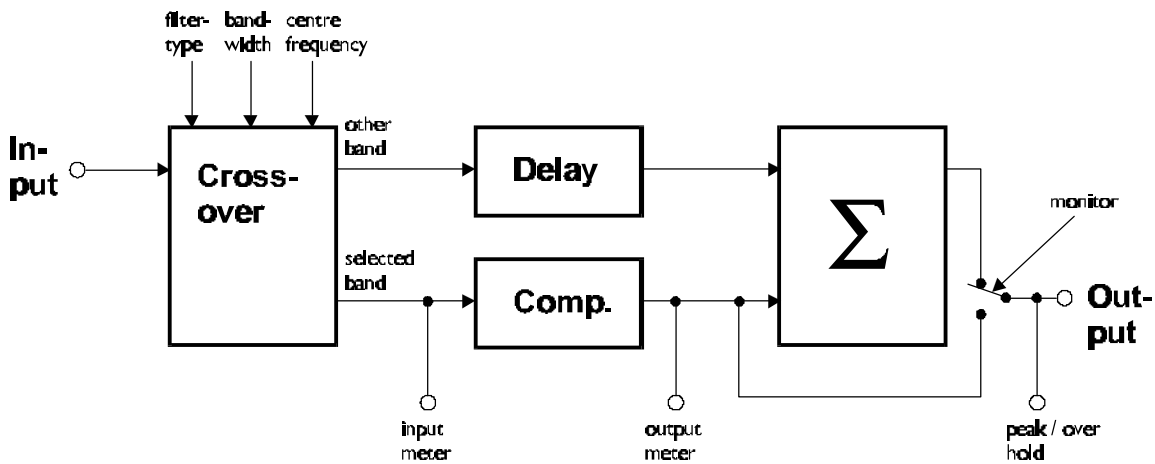

Graphic 7: Band Selective Mode

Band Selective Mode (Graphic 7): In this mode, a frequency crossover is put into the signal path, splitting it up into two or three bands, depending on the filter type setting. One of the bands is compressed, the other is delayed by the same amount used as „delay“ in the compressor stage (see Graphic 4). This mode is completely transparent if no gain reduction is applied.

A special feature of this mode is the **monitor** function.

Full Range Mode (Graphic 8): Since this mode uses double sampling processing for the compressor, the signal has to be up- and downsampled. In this mode, the peak meters are in fact situated at the in- and output of the DS1, and the monitor key has no function.

Because of the up- and downsamplers, the full range mode is not bit transparent, even if no gain reduction is applied. Bypass has to be activated to achieve bit transparency.

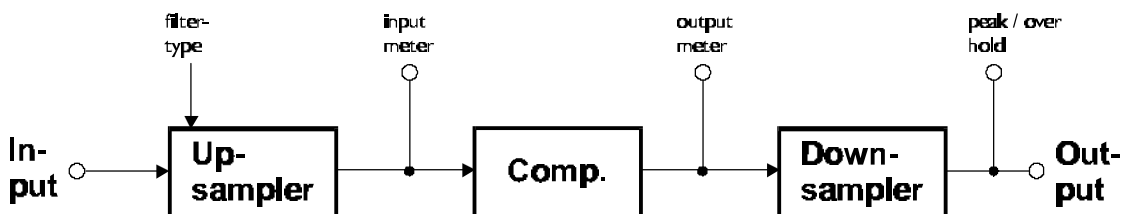

Graphic 8: Full Range Mode

Safe

Pressing the safe key will disable control from the front panel.

Presets

The DS1 has easily accessible presets (③) for a quick setup which can then be refined and adapted to the programme being processed. These presets are grouped according to their function:

De-Esser: Four applications for high-frequency transients removal. Adjust threshold and cross-over frequency as required.

Limiter: Three settings for loudness maximizing - experiment with the transfer curve parameters for a programme optimized result. The last setting uses the crossover to select the low-band and applies a small gain, hence „bass boost“.

Dither

The DS1 is able to apply shaped dither noise to remove distortion when re-quantizing from 24bit to 16bit or 20bit output word length (see TECHNICAL DATA for dither specifications).

To toggle dither on/off, press key D twice. To see dither status refer to the status display (③, see Status Display p. 5).

Word Length

To set output word length, press key D

Auto-Blacking

If auto-blacking is activated by marking the “0 IN → 0 OUT” option, dither will be turned off if the input signal is zero. As soon as the input signal changes, dither will be turned on again. This ensures that breaks between programmes are still digital zero, even if dither is activated.

Snapshots

Snapshots are copies of the DS1 parameter settings. This allows recalling complete set-ups including all parameters and controls settings.

Snapshots can be recalled from the front panel or by remote control (e.g. MIDI Program Change).

Snapshot access keys are in ②. To see workspace status refer to the status display (③, see Status Display p. 5).

A-B Comparison

You can compare two settings by using the two workspaces “A” and “B”. To toggle between the two press the “A-B” key. Restore a snapshot or simply adjust parameters in one workspace, then switch to the other to compare.

To copy workspace “A” to “B” or vice versa, press the “copy” key and select an option (Graph 9).

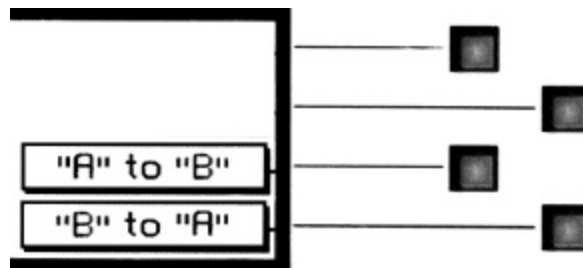

Graph 9: "copy" menu

The active workspace is shown in the status display.

Recall

To recall a snapshot press the “recall” key. Notice that the snapshot will be copied into the active workspace. If you do not want to lose these settings, switch to the other workspace by pressing the “A-B” key.

Using the gain/ data knob (④) enter the number of the snapshot you want to recall. The graph of the snapshot will be displayed. However, the audio signal is not affected if the “Preview” option is marked. Once you have found the snapshot, press key D to restore it.

If the “Preview” option is not marked, the snapshots will be recalled as soon as you enter a new number.

Press the “recall” key to return to the status display.

“Recall #0”

Snapshot 0 can be use to quickly reset the DS1.

Store

To store the current workspace to a snapshot, press the “store” key. With the gain/ data knob (4) enter the snapshot number where you want to store the workspace, then press key D. Snapshots can be prevented from accidental erasure by marking the “Safe” option.

A setting can be stored to multiple snapshots. Press “To Range” in the “store” menu.

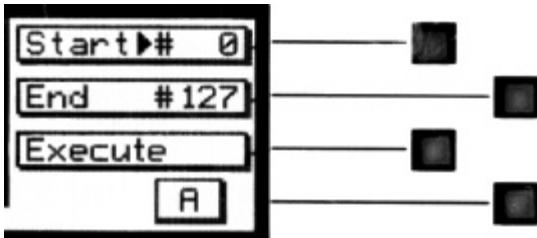

Graph 10: Store To Range Menu

Press the adjacent keys to select “Start” and “End” snapshot number, use the “gain/ data” encoder to enter a value (Graph 10). Pressing “Execute” will store the setting from the displayed workspace (“A” or “B”) to all snapshots between the Start and End value. A “Safe” snapshot will not be overwritten.

Backup

All 128 snapshots can be transferred to another non-volatile memory area for later reference. There is enough memory for two complete snapshot sets to be backed up.

Press the “menu” key (1) then choose the “Snapshots” and then the “Backup” option to arrive at the backup display (Graph 11).

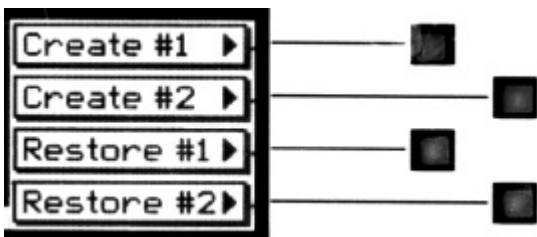

Graph 11: Backup Display

Select “Create #1” to save the current snapshots to bank 1. Select “Restore #1” to overwrite the current snapshots with bank 1 (ditto for bank 2).

A backup will overwrite “safe” snapshots.

Reset

To reinstall the factory snapshots you must press the “menu” key then choose the “Snapshot” and then the “Reset all” option. This will reset the current snapshots. The snapshots that have been backed up are preserved.

Dump

The settings of all 128 snapshots can be dumped to a remote control port to be stored externally. Please make sure that you have connected everything correctly and that the proper remote control port is activated (see chapter Remote Control for setup).

When dumping to a MIDI-sequencer, make sure that the sequencer is not sending or receiving data other than the snapshot dump.

Certain sequencers are not capable of handling the amount of data output by the DS1 and might crash during or after the dump process.

To initiate a dump, press the “menu” key then choose the “Snapshot” and then the “Dump” option. Start the recording process on the sequencer, then press “Transmit”. This releases the dump to the sequencer.

Loading

To load a snapshot dump from sequencer, simply play the dump sequence. The DS1 will automatically switch into receive mode and display statistics about the snapshots it’s receiving. If the transmission was OK, the program switches back to normal mode. Upon error, you have to manually switch back to normal mode.

When playing back the dump sequence, always use the same speed as when the sequence was recorded.

Meter Resolution

The transfer graph and the compressor peak meters (⑥) work with different resolutions to accommodate signals with a wide dynamic range.

The resolution for the peak meters and transfer graph can be set in fixed steps of -20dB, -40dB and -80dB, or alternatively, to auto. In auto mode, the display switches to the next step as soon as the transfer graph falls below the current window. The peak meters resolution is always the same as the transfer graph's.

The same principle applies to the gain reduction meter (④).

To adjust gain reduction or peak meter resolution, press the „menu“ key (ⓘ) and press the „Display“ softkey. Then use keys A and B to select either „gain reduction“ or „curve“ to change the resolution of the corresponding graphs. Use the gain / data knob (④) to alter values.

LCD Contrast

To change the display contrast, press the „menu“ key (ⓘ), then „Display“. Press key C to activate „LCD Contrast“. Adjust contrast with the gain / data encoder.

DS1 Bypass

The DS1 can be completely bypassed with the green „bypass“ key below the mains switch. If the „bypass“ key is lit, the DS1 is absolutely transparent, making the output signal bit equal to the input signal. However, the overall delay (see chapter Delay) is still active.

While bypass is active (key is lit), the DS1 works in preview mode. This allows you to change parameters without actually affecting the audio signal.

Remote Control

All band parameters as well as control settings can be set externally.

To see remote control status refer to the status display (③, see Status Display p. 5).

Protocol

To select a remote control protocol, press key C from the status display menu. Select either „RS 232“, „RS 422“ or „MIDI“. This will determine which port at the rear of the DS1 is active. The other inactive ports will be ignored.

Press the „menu“ key to return to the status display if you do not want to change remote on/ off status.

When selecting a port other than MIDI you have to specify the baud rate. Refer to the remote control software manual for correct settings. The set baud rate is displayed to ensure proper set-up.

Channel

To change the remote control channel number, press key C (adjacent to the remote control field). Use the gain/ data knob (④) to select a value between 1 and 16. Press the „menu“ key to return to the status display. Omni mode (listening on all channels simultaneously) is not supported.

On/ Off

To enable or disable remote control, press key C (adjacent to the remote control field). Press it again to toggle the „ON/ OFF“-value.

While remote control is off, data will still be sent to the selected port. Also, the MIDI THRU output will always mirror the MIDI IN input data regardless of „ON/ OFF“ or protocol status.

Software Information

Press the „menu“ key (ⓘ), then select the „System“ and the „About“ option. This displays a screen with all the relevant information on your DS1 and how to reach us. Have this page ready when you want to report a problem.

TECHNICAL DATA

AES/EBU Input

Sampling Frequencies:	44.1 kHz or 48.0 kHz
Maximum Input Wordlength:	24 Bits
Channel Status Data:	Input accepts professional or consumer format.
Channel Status Bits forwarded to AES/EBU output:	see table below
Connector:	XLR female

AES/EBU Output

Sampling Frequencies:	44.1 kHz or 48.0 kHz
Output Wordlength:	24 Bits
Connector:	XLR male

AES/EBU Channel Status Data

The DS1 allows to convert the incoming Channel Status Data as follows:

- ✦ From Consumer to Professional
- ✦ From Professional to Consumer
- ✦ Transparent mode, i.e. Channel Status Data is fed forward to the output without any conversion (one exception, see below)

The following tables describe how the Channel Status Data bits are generated in the various conversion modes.

Output selected: Consumer format.

Input: Consumer format.

Output: All bits fed forward (transparent), except for:
 Byte 1: Bits 0..6: 0000000 (category code general)
 Bit 7: 1 (original)

Input: Professional format.

Output:
 Byte 0: Bit 0: 0 (consumer)
 Bit 1: 0 (audio)
 Bit 2: 1 (copy allowed)
 Bits 3,4: Preemphasis according to input
 Bit 5: 0 (2 channel mode)
 Bits 6,7: 00 (Mode 0)

Byte 1: Bits 0..6: 0000000 (category code general)
 Bit 7: 1 (original)

Byte 2: Bits 0,1,2,3: Sampling Frequency according to input

Bits 4,5: 00 (accuracy grade II)
Bits 6,7: 00

Bytes 3..23: reserved bytes

Output selected: Professional format.

Input: Professional format.

Output: All bits fed forward (transparent), except for:

Byte 2: Bits 0,1,2: 001 (max. sample length= 24bit)
Bits 3,4,5: 101 (24 bit word length)
Bits 6,7: 00

Input: Consumer format.

Output:

Byte 0: Bit 0: 1 (professional)
Bit 1: 0 (audio)
Bits 2,3,4: Preemphasis according to input
Bit 5: 0 (source fs locked)
Bits 6,7: Sampling Frequency according to input

Byte 1: Bits 0,1,2,3: 0001 (two channel mode)
Bits 4,5,6,7: 0000 (no user bit encoding)

Byte 2: Bits 0,1,2: 001 (max. sample length= 24bit)
Bits 3,4,5: 101 (24 bit word length)
Bits 6,7: 00

Bytes 3..12: All bits 0

Byte 23: CRCC byte

Output selected: Transparent.

Input: Any format.

Output: All bits fed forward (transparent), except if not bypassed:

Byte 2: Bits 0,1,2: 001 (max. sample length= 24bit)
Bits 3,4,5: 101 (24 bit word length)
Bits 6,7: 00

Power

Mains Voltage:	110 / 220 Volts with voltage selector
Fuse rating:	500 mA slow blow
Power Consumption:	40VA max

Overload

Number of consecutive over-samples to cause "over" display:	1..16 settable
-------------------------------------------------------------	----------------

Peak Meters

Peak meters timing for compressor input and output stage adhere to AES recommendations.

Parameter Table

Overall Gain

All numbers in dB:

- ∞, - 90.0, -85.0, -80.0, -76.0, -72.0, -68.0, -64.0, -60.0, -56.0, -53.0, -50.0, -48.0, -46.0, -44.0, -42.0, -40.0, -39.0, -38.0, -37.0, -36.0, -35.0, -34.0, -33.0, -32.0, -31.0, -30.0, -29.5, -29.0, -28.5, -28.0, -27.5, -27.0, -26.5, -26.0, -25.5, -25.0, -24.5, -24.0, -23.5, -23.0, -22.5, -22.0, -21.5, -21.0, -20.5, -20.0, -19.5, -19.0, -18.5, -18.0, -17.5, -17.0, -16.5, -16.0, -15.5, -15.0, -14.5, -14.0, -13.5, -13.0, -12.5, -12.0, -11.5, -11.0, -10.5, -10.0, -9.5, -9.0, -8.5, -8.0, -7.5, -7.0, -6.5, -6.0, -5.8, -5.6, -5.4, -5.2, -5.0, -4.8, -4.6, -4.4, -4.2, -4.0, -3.8, -3.6, -3.4, -3.2, -3.0, -2.8, -2.6, -2.4, -2.2, -2.0, -1.8, -1.6, -1.4, -1.2, -1.0, -0.8, -0.6, -0.5, -0.4, -0.3, -0.2, -0.1, 0.0, 0.5, 1.0, 1.5, 2.0, 2.5, 3.0, 3.5, 4.0, 4.5, 5.0, 5.5, 6.0, 6.5, 7.0, 7.5, 8.0, 8.5, 9.0, 9.5, 10.0

Bandwidth

All numbers are fractions of octaves:

1/6, 1/3, 1/2, 2/3, 5/6, 1, 11/6, 1 1/3, 1 1/2, 1 2/3, 1 5/6, 21/6, 2 1/3, 2 1/2, 2 2/3, 2 5/6, 31/6, 3 1/3, 3 1/2, 3 2/3, 3 5/6, 4 1/6, 4 1/3, 4 1/2, 4 2/3, 4 5/6, 51/6, 5 1/3, 5 1/2, 5 2/3, 5 5/6, 6

Frequency

All numbers are Herz and are either center or cutoff frequency:

277, 294, 311, 330, 349, 370, 392, 415, 440, 466, 494, 523, 554, 587, 622, 659, 698, 740, 784, 831, 880, 932, 988, 1050, 1110, 1170, 1240, 1320, 1400, 1480, 1570, 1660, 1760, 1860, 1980, 2090, 2220, 2350, 2490, 2640, 2790, 2960, 3140, 3320, 3520, 3730, 3950, 4190, 4430, 4700, 4980, 5270, 5590, 5920,

6270, 6640, 7040, 7460, 7900, 8370, 8870, 9400, 9960, 10500, 11200, 11800, 12500, 13300, 14100, 14900, 15800, 16700, 17700

Attack, Release Delay, Release Fast & Slow, Average, Preview (when applicable):

All numbers are in seconds:

20 μ , 40 μ , 60 μ , 80 μ , 100 μ , 125 μ , 160 μ , 200 μ , 250 μ , 315 μ , 400 μ , 500 μ , 630 μ , 800 μ , 1m, 1.25m, 1.60m, 2.00m, 2.50m, 3.15m, 4.00m, 5.00m, 6.30m, 8.00m, 10.0m, 12.5m, 16.0m, 20.0m, 25.0m, 31.5m, 40.0m, 50.0m, 63.0m, 80.0m, 100m, 125m, 160m, 200m, 250m, 315m, 400m, 500m, 630m, 800m, 1, 1.25, 1.60, 2.00, 2.50, 3.15, 4.00, 5.00, 6.30, 8.00

$\mu = 10^{-6}$

m = 10^{-3}

Soft-knee:

0.0, 0.1, 0.2, 0.3, 0.4, 0.5, 0.6, 0.7, 0.8, 0.9, 1.0

Threshold:

All numbers are in dB:

0, -1, -2, -3, -4, -5, -6, -7, -8, -9, -10, -11, -12, -13, -14, -15, -16, -17, -18, -19, -20, -21, -22, -23, -24, -25, -26, -27, -28, -29, -30, -31, -32, -33, -34, -35, -36, -37, -38, -39, -40, -41, -42, -43, -44, -45, -46, -47, -48, -49, -50, -51, -52, -53, -54, -55, -56, -57, -58, -59, -60

Ratio:

1.00:1, 1.05:1, 1.11:1, 1.17:1, 1.25:1, 1.33:1, 1.43:1, 1.54:1, 1.67:1, 1.81:1, 2.00:1, 2.22:1, 2.50:1, 2.86:1, 3.33:1, 4.00:1, 5.00:1, 6.66:1, 10:1, 20:1, 1000:1

Gain Makeup:

All numbers are in dB:

-10, -9, -8, -7, -6, -5, -4, -3, -2, -1, 0, 1, 2, 3, 4, 5, 6, 7, 8, 9, 10, 11, 12, 13, 14, 15, 16, 17, 18, 19, 20, 21, 22, 23, 24, 25, 26, 27, 28, 29, 30, 31, 32, 33, 34, 35, 36, 37, 38, 39, 40, 41, 42, 43, 44, 45, 46, 47, 48, 49, 50, 51, 52, 53, 54, 55, 56, 57, 58, 59, 60

off, max.

Dither

Dithering algorithm is implemented using second order noise shaping, as can be seen in Graph 12.

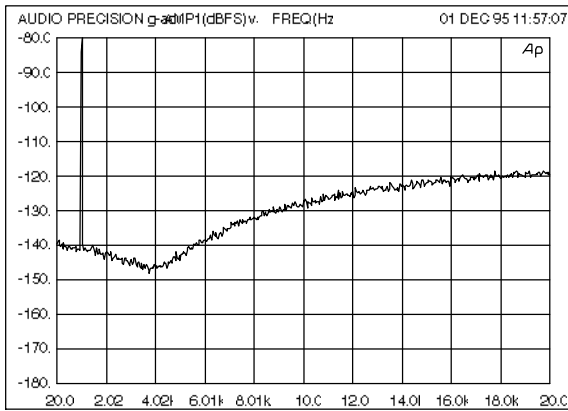

Graph 12: Output spectrum with 80dBFS / 1kHz sine wave, dithered to 16 Bits

Remote

MIDI Implementation

System Inclusive

All band parameters plus the controls parameters are remote controllable. Each parameter has its corresponding MIDI controller number.

According to the different parameters, the controllers are limited in their range. Invalid values are replaced by the maximum allowable value. Following is a list of the supported MIDI commands:

Action	MIDI Message	Status Byte	Data Byte(s)	Comment
Restore Snapshot	Program Change	1100 cccc	0ppp pppp	(cccc) Channel No. (ppppppp) New Prog No: 0 - 127
Center Frequency	Control Change	1011 cccc	00000000 (\$00) 0vvv vvvv	(cccc) Channel No. (vvvvvv) New Value: 0 - 72
Bandwidth	Control Change	1011 cccc	00000001(\$01) 0vvv vvvv	(cccc) Channel No. (vvvvvv) New Value: 1 - 36
Filter Mode	Control Change	1011 cccc	00000010 (\$02) 0vvv vvvv	(cccc) Channel No. (vvvvvv) New Value: 0= limiter, 1= Bandpass, 2 = Lowpass, 3 = Hipass
Predelay	Control Change	1011 cccc	00000011 (\$03) 0vvv vvvv	(cccc) Channel No. (vvvvvv) New Value: 0 - 37
Attack	Control Change	1011 cccc	00000100 (\$04)	(cccc) Channel No.

			0vvv vvvv	(vvvvvv) New Value: 0 - 43
Release Delay	Control Change	1011 cccc	00000101 (\$05) 0vvv vvvv	(cccc) Channel No. (vvvvvv) New Value: 0 - 53
Release Fast	Control Change	1011 cccc	00000110 (\$06) 0vvv vvvv	(cccc) Channel No. (vvvvvv) New Value: 0 - 53
Average	Control Change	1011 cccc	00000111 (\$07) 0vvv vvvv	(cccc) Channel No. (vvvvvv) New Value: 0 - 53
Release Slow	Control Change	1011 cccc	00001000 (\$08) 0vvv vvvv	(cccc) Channel No. (vvvvvv) New Value: 0 - 53
Soft Knee	Control Change	1011 cccc	00001001 (\$09) 0vvv vvvv	(cccc) Channel No. (vvvvvv) New Value: 0 - 10
Gain Makeup Mode	Control Change	1011 cccc	00001010 (\$0A) 0vvv vvvv	(cccc) Channel No. (vvvvvv) New Value: 0= off, 1 = manual, 2= maximum
Ratio	Control Change	1011 cccc	00001011 (\$0B) 0vvv vvvv	(cccc) Channel No. (vvvvvv) New Value: 0 - 20
Threshold	Control Change	1011 cccc	00001100 (\$0C) 0vvv vvvv	(cccc) Channel No. (vvvvvv) New Value: 0 - 60
Gain Makeup	Control Change	1011 cccc	00001101 (\$0D) 0vvv vvvv	(cccc) Channel No. (vvvvvv) New Value: 0 - 70
Output Gain	Control Change	1011 cccc	00001110 (\$0E) 0vvv vvvv	(cccc) Channel No. (vvvvvv) New Value: 0 - 127
Bypass	Control Change	1011 cccc	00001111 (\$0F) 0vvv vvvv	(cccc) Channel No. (vvvvvv) New Value: 0= off, 1 = on
A-B Select	Control Change	1011 cccc	00010000 (\$10) 0vvv vvvv	(cccc) Channel No. (vvvvvv) New Value: 0= WS A, 1 = WS B
Monitor	Control Change	1011 cccc	00010010 (\$12) 0vvv vvvv	(cccc) Channel No. (vvvvvv) New Value: 0= off, 1 = on
System Reset		1111 1111	-	Recall Snapshot 0 to WS A

System Exclusive

Snapshot format:

Bytecount	Value	Description	
1	F0	Sysex	Header
2	00	Manufacturer's ID	
3	30	Manufacturer's ID	
4	5A	Manufacturer's ID	
5	08	Model ID: 8 = Gambit DS1	
6	0000nnnn	Device ID: -> Midi channel number	
7	00000001	message = Snapshot dump	Message Type 1
8	0nnnnnnn	Package number (0..7F)	Data
9	0nnnnnnn	scale set number	
10 - 24	0nnnnnnn	15 Bytes of Snapshot data	
25	0ccccccc	Checksum without byte one (F0 Sysex Command)	Checksum
26	F7	EOS	EOS

Dump request:

Bytecount	Value	Description	
1	F0	Sysex	Header
2	00	Manufacturer's ID	
3	30	Manufacturer's ID	
4	5A	Manufacturer's ID	
5	08	Model ID: 8 = Gambit DS1	
6	0000nnnn	Device ID: -> Midi channel number	
7	00000010	message = dump request	Message Type 2
8	F7	EOS	EOS

Version request:

Bytecount	Value	Description	
1	F0	Sysex	Header
2	00	Manufacturer's ID	
3	30	Manufacturer's ID	
4	5A	Manufacturer's ID	
5	08	Model ID: 8 = Gambit DS1	
6	0000nnnn	Device ID: -> Midi channel number	
7	00000011	message = version request	Message Type 3
8	F7	EOS	EOS

Version send:

Bytecount	Value	Description	
1	F0	Sysex	Header
2	00	Manufacturer's ID	
3	30	Manufacturer's ID	
4	5A	Manufacturer's ID	
5	08	Model ID: 8 = Gambit DS1	
6	0000nnnn	Device ID: -> Midi channel number	
7	00000100	message = send version	Message Type 4
8	00000100	OS Version	data
9	00000100	DSP Version	
10	00000100	Scale Version	
11	00000100	Coeff. Version	
12	F7	EOS	EOS

PC programming mode:

Bytecount	Value	Description	
1	F0	Sysex	Header
2	00	Manufacturer's ID	
3	30	Manufacturer's ID	
4	5A	Manufacturer's ID	
5	08	Model ID: 8 = Gambit DS1	
6	0000nnnn	Device ID: -> Midi channel number	
7	00000101	message = pc programming mode	Message Type 5
12	F7	EOS	EOS

Addendum to the Manuals of the Gambit Series DS1 and DS1-MK2 DeEsser / Compressor / Limiter

The graphs on the pages below have been made to convey a better understanding of the dynamic parameters of the Gambit DS1 DeEsser/Compressor.

Please also read the appropriate pages in the DS1 / DS1-MK2 manual to have a proper understanding of the sidechain process.

The test signal is a repeating sine wave burst with a certain "on" and a certain "off" level. The frequency of the sine wave is above 10kHz (period less than 100 μ s), so there is no influence of the sine wave frequency on the timing behaviour.

The table below shows the timing parameters set on the DS1. For the static parameters a threshold of -20dB, a 1000:1 ratio and no softknee have been chosen.

Figure	Preview	Attack	Rel.Delay	Rel.Fast	Average	Rel.Slow	burst duty cycle
1	bypass						
2	20 μ s	20ms	20 μ s	200ms	800ms	1s	50%
3	63ms	"	"	"	"	"	"
4	"	"	"	"	"	200ms	"
5	"	"	5ms	"	"	"	"
6	"	"	20ms	"	"	"	"
7	"	"	"	25ms	"	500ms	0.5%
8	"	"	"	"	"	"	2%
9	"	"	"	"	"	"	5%
10	"	"	"	"	"	"	10%
11	"	"	"	"	40ms	"	0.5%
12	"	"	"	"	"	"	2%
13	"	"	"	"	"	"	5%
14	"	"	"	"	"	"	10%

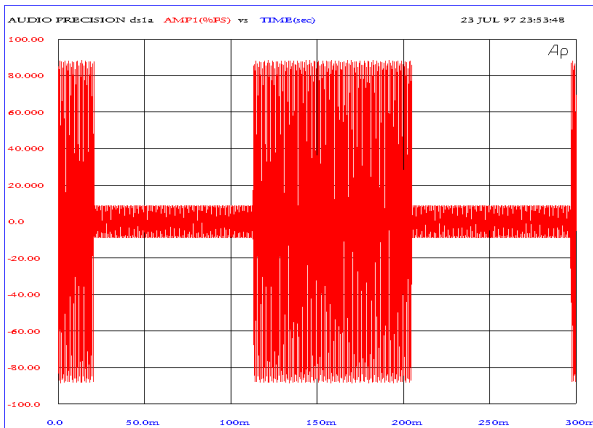

Fig. 1

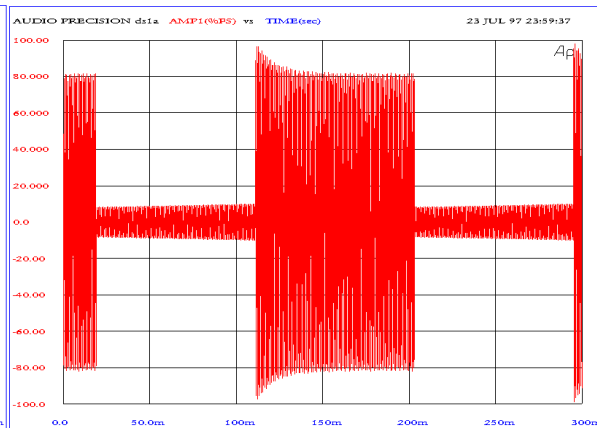

Fig. 2

Fig. 1 Bypass, this is how the 50% duty cycle sinewave burst looks like. X-axis shows time in milliseconds, Y-axis shows linear level in percentage of full scale. Just like a scope.

Fig. 2 A very short preview time combined with a long attack time cause an overshoot at the onstart of the burst. As the sidechain reacts to the input signal (slowly because of the long attack time) the level of the burst is brought to the anticipated level.

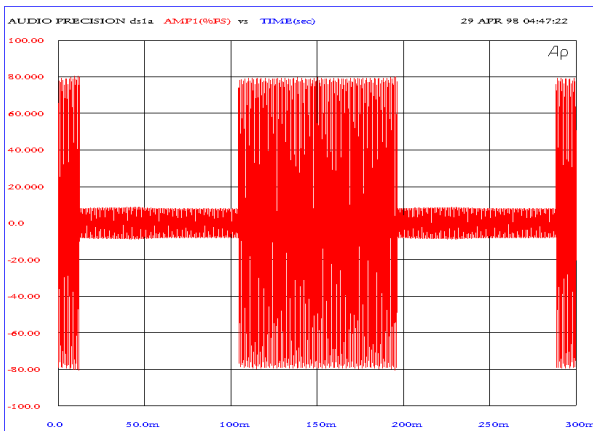

Fig. 3

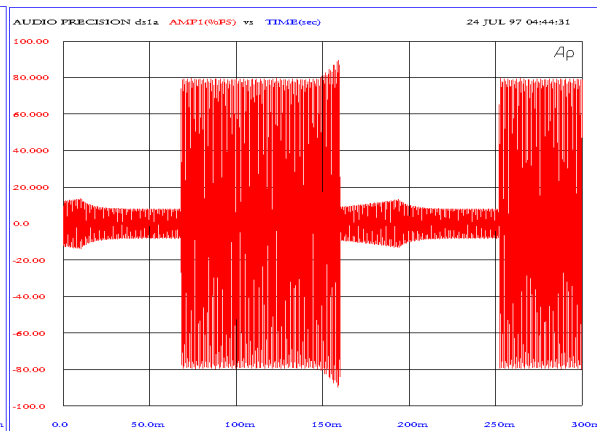

Fig. 4

Fig. 3 The preview time is now about three times the attack time, which gives the sidechain a headstart on the audio signal. The result is a proper limiting without overshoot.

Fig. 4 As useful the preview facility in Fig 3 is, it can have an unwanted effect at the release portion. A relatively short release time causes the release to show up during the last milliseconds of the burst. This because the sidechain "sees" the "burst off" before the gain stage sees it (preview delay), so the end of the burst gets influenced by the release.

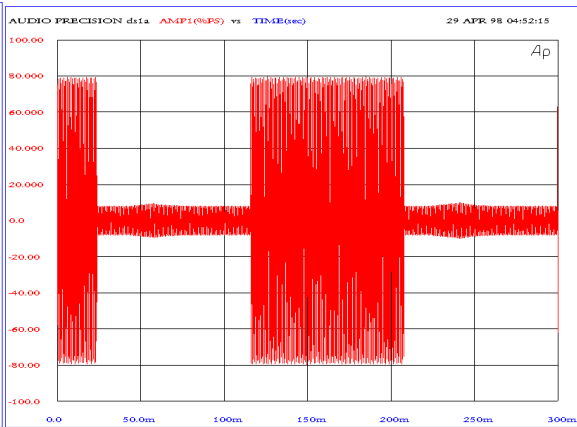
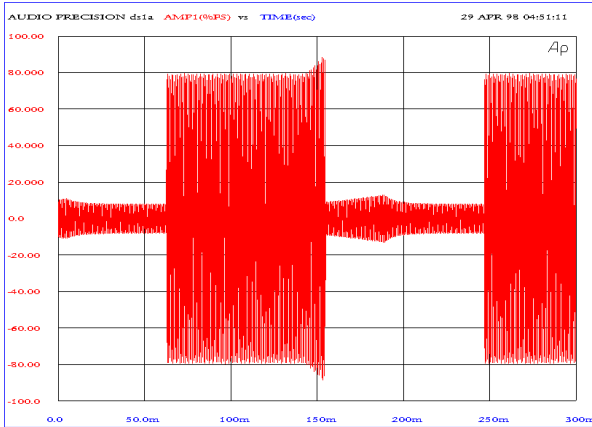

Fig. 5

Fig. 6

Figs. 5 and 6 The effect described in Fig. 4 can be eliminated with the Release Delay parameter. The release is delayed for a certain time and thus can not influence the end of the burst anymore. In Fig 5 the release delay is not quite long enough, while in Fig. 6 there is no release influence visible anymore.

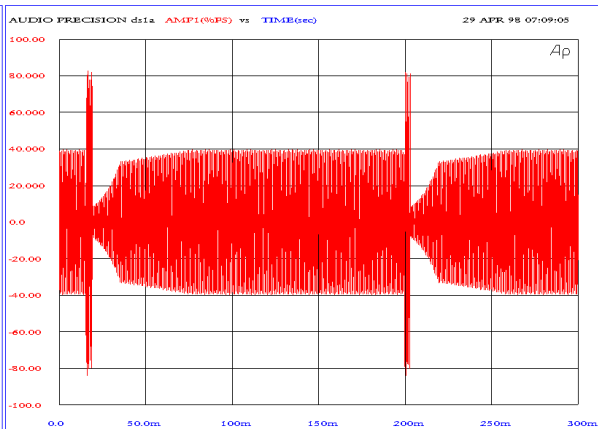
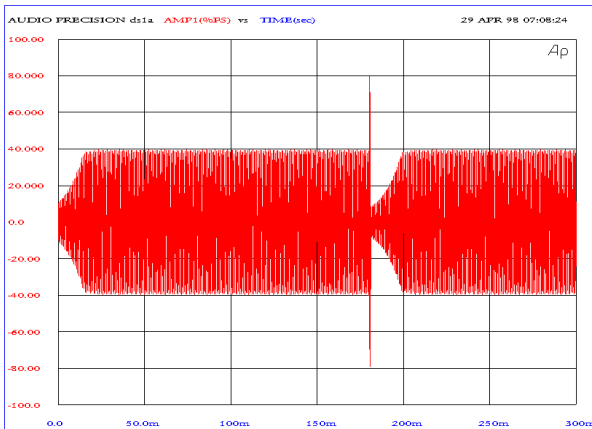

Fig. 7

Fig. 8

The following figures show the effect of the automatic release time algorithm and the Average parameter.

Fig. 7 A very short burst duration, like a short peak in the music. The Release Fast, Average and Release Slow parameters are set to typical values. Fig. 7 shows that after a short peak the Release Fast time is chosen, so that the short peak does not have much influence on the programme after it.

Fig. 8 The burst is now longer which gives it more influence on the average measurement (averaging off the signal). First there is a Release Fast portion followed by a short segment of Release Slow.

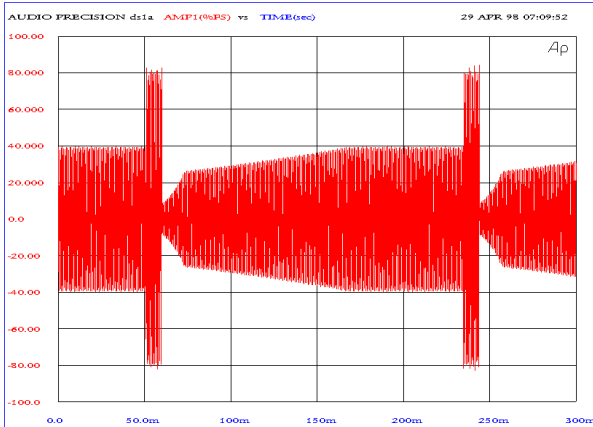

Fig. 9

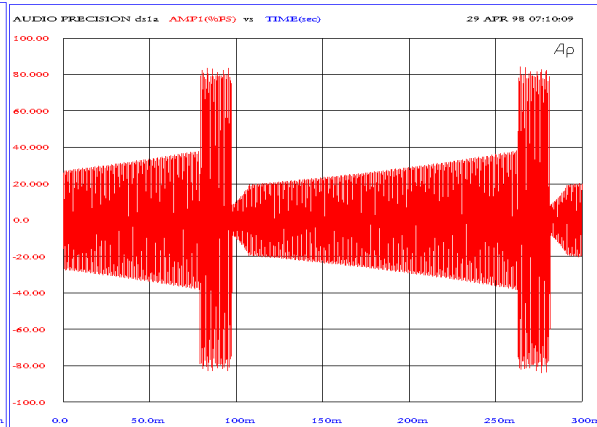

Fig. 10

Fig. 9 The burst is even longer, causing a longer Release Slow portion.

Fig. 10 Still longer burst, with even longer Release Slow portion.

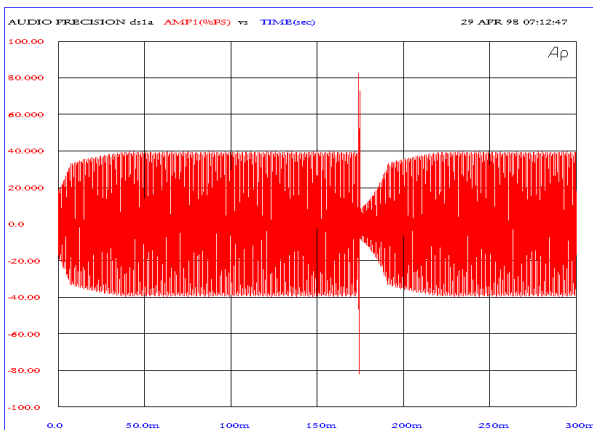

Fig. 11

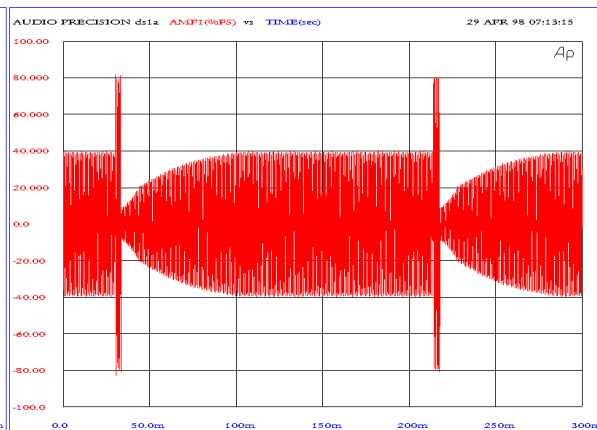

Fig. 12

Figs. 11 to 14 For these figures the Average time is relatively short, causing the average measurement value to follow the peak measurement more quickly than with Fig. 7 to 10. The effect is that depending on the burst length, there is not that much of an influence of the Release Slow parameter as it was with figures 7 to 10.

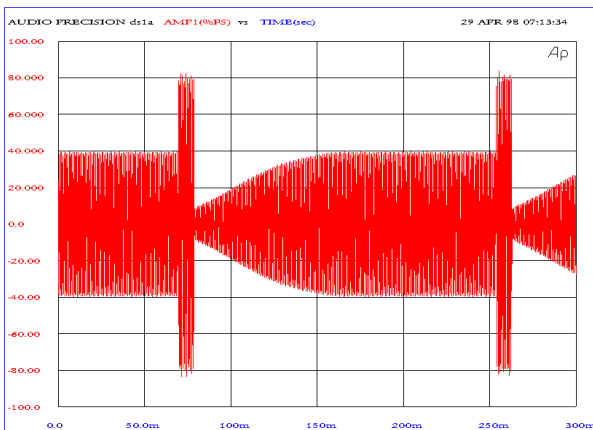

Fig. 13

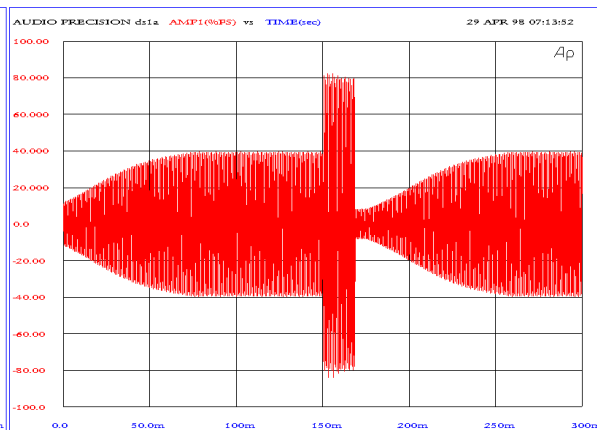

Fig. 14